



more **yield**
from your **field**

with air-assist harvesting



Scan above to find
parts books

AWS Limited Warranty Policy

Warranty

- 1.1 S3 AWS warrants that all Product purchased from S3 AWS shall be free from defects in workmanship and materials for a period of one (1) year from date S3 AWS invoices the original Customer ("Warranty Period").
- 1.2 The Warranty described herein is provided by S3 to the original purchaser of the Product. The Warranty is non-transferable.
- 1.3 S3 AWS, at its option, will repair or replace any part covered by the Warranty in Section 1.1 during the Warranty Period on the following conditions:
 - (a) Customer shall notify S3 AWS of the defect within thirty (30) days of failure;
 - (b) Customer shall produce proof of purchase and warranty eligibility together with photographs and/or such other proof of failure as may be required of Customer in Section 3.1.
 - (c) S3 AWS shall determine in its sole and absolute discretion whether the defect or failure is covered by the Warranty;
 - (d) S3 AWS, in its sole discretion, may contract out any repairs to the Customer or repair agent of its choice.
- 1.4 Eligible warranty repairs or replacement shall be free of charge to the original purchaser for materials, labor and shipping in Year 1 of the Warranty Period.
- 1.5 S3 AWS shall be responsible for the repair or replacement of:
 - (a) Defective parts or subassemblies incorporated in the Product that are warranted under original manufacturing warranties from OEM or third party suppliers;

Not Covered By Warranty

- 2.1 S3 AWS shall not be responsible for the repair or replacement of:
 - (a) Products that have been altered or modified in any manner not approved or authorized by S3 AWS; or
 - (b) Damage caused by normal wear and tear, lack of reasonable proper maintenance, misuse, excessive use, or damage caused by accident, vandalism or Act of God.

Purchaser Responsibilities

- 3.1 In order to establish eligibility for the Warranty set out herein, the Customer shall:
 - (a) Notify S3 AWS of the defect within thirty (30) days of date of failure;
 - (b) Upon request by S3 AWS, produce the following proof of purchase ("Proof of Eligibility") within thirty (30) days of request by S3 AWS: Part Number; Serial Number; Quantity; Failure Date; Description of Failure; Other.
 - (c) If so requested by S3 AWS, Customer shall within thirty (30) days of request:
 - (i) Furnish photographs and/or such further supporting evidence as may be required by S3 AWS to support the warranty claim;
 - (ii) Return the Product to S3 AWS as requested by Return Merchandise Authorization ("RMA").

- (iii) Make the repair itself or deliver the Product to the repair agent as requested by S3 AWS.
- 3.2 Where Customer is authorized by S3 AWS to make the repairs, the Customer's account shall be credited for the cost of the repairs, provided:
 - (a) Customer provides S3 AWS a detailed scope of work, labour hours required to complete the work, hourly rate and material costs ("Work");
 - (b) S3 AWS approves the Work based on the details provided in para. (a);
 - (c) The warranty repairs and services are completed in a good and workmanlike manner according to prevailing industry standards;
 - (d) The repairs are made in accordance with labour rates and price lists approved by S3 AWS, or as prescribed by local provincial or State laws;
 - (e) Customer obtains the prior approval of S3 AWS if field diagnostic inspection is required. Travel and expenses must be pre-approved.

If the Customer proceeds with the Work prior to receiving written approval from S3 AWS, S3 AWS will have the right, in its sole and absolute discretion, to reject the warranty claim and to refuse to apply credit to the Customer's account.

- 3.3 Where Customer is requested to return Product to S3 AWS or to deliver to a designated repair agent, the Customer will ship the defective part or Product via the common carrier designated by S3AWS in the RMA, at S3 AWS's cost. S3 AWS will initiate Credit or replacement for the Product when/if Warranty has been approved

S3 AWS Responsibilities

- 4.1 S3 AWS shall reply to the Customer's warranty notice in paragraph 3.1(a) within fifteen (15) days of notification.
- 4.2 Upon receipt of the Proof of Eligibility set out in para. 3.1(b), S3 will evaluate the warranty claim and will notify Customer as to whether the Product is eligible for repair or replacement under the Warranty upon completion of its evaluation.
- 4.3 If the Product is eligible for Warranty, S3 may request return of the Product to S3 AWS, the Customer or to such other repair agent as S3AWS may choose by issuing an RMA, or may elect to credit Customer's account for the Customer's cost of the Product.
- 4.4 S3 AWS will credit all shipping costs on all approved warranty repairs provided Customer complies with the shipping and related instructions in the RMA.

Warranty & Liability Limitations

- 5.1 The Warranty provisions herein constitute the full extent of the warranties supplied by S3 AWS for the Product.
- 5.2 S3 AWS reserves the absolute and unconditional right to deny or reverse its approval of any Warranty claim in the case of fraud, abuse or error.
- 5.3 Without limiting the generality of the foregoing and to the extent permitted by law, S3 AWS HEREBY expressly disclaims AND excludes all warranties and conditions of merchantability AND fitness for A PARTICULAR purpose, whether express or implied, statutory or otherwise
- 5.4 Where the exclusion of implied or statutory warranties or conditions is prohibited by law, any such warranties or conditions shall be limited in duration to the warranty period set out herein.

Temp Farm Equipment Ltd.

3890 Wellington St. Box 269 Mitchell, Ontario Canada N0K-1N0
519-348-0066 www.awsairbar.com

- 5.5 SUBJECT TO ANY STATUTORY EXCEPTIONS OR LIABILITY IMPOSED BY LAW, S3 AWS's LIABILITY FOR ANY CAUSE WHATSOEVER (INCLUDING NEGLIGENCE) IS HERBY LIMITED TO ACTUAL DAMAGES IN SUCH AN AMOUNT AS NOT TO EXCEED THE PURCHASE PRICE OF THE PRODUCT GIVING RISE TO THE WARRANTY CLAIM.
- 5.6 IN NO EVENT SHALL S3 AWS BE LIABLE FOR ANY INCIDENTAL, INDIRECT, SPECIAL OR CONSEQUENTIAL DAMAGES, EVEN IF ADVISED OF THE POSSIBILITY THEREOF, INCLUDING DAMAGES FOR LOSS OF USE OF THE PRODUCT, OR LOSS OF BUSINESS OR PROFITS AS A RESULT.

General

- 6.1 This Warranty shall be governed by and subject to the Terms & Conditions of Sale of the Product, including without limitation "Limited Warranty" and "Governing Law" provisions thereof.
- 6.2 For greater clarity, and subject to any local laws or statutes to the contrary, the provisions of this Warranty shall be governed by the laws of the Province of Alberta, and shall be subject to the exclusive jurisdiction of the courts therein.

Table of Contents

AWS Limited Warranty Policy	2	Manifold / Air Ducting	25
Introduction	6	Fastener Torque	25
Foreword	6	Bolt Grade / Class Identification	25
Items Included with Airbar® Kits	6	Troubleshooting Guide	26
Serial Number Location	7		
Replacement Parts Information	7		
Unauthorized Modification	7		
Misuse of Equipment	7		
Product Design	7		
Official Language	8		
Component Identification	9		
Safety	11		
Safety Alert Symbol	11		
Hazard Seriousness Level	11		
General Safety Precautions	11		
Power Unit Safety	12		
Operating Equipment Safely	12		
Safety Decals	13		
System Setup for Operation	14		
Feeder House Dust Extraction	14		
When Connecting the Header	14		
When Disconnecting the Header	14		
Electrical Controls	15		
Operating the System	16		
Daily Checks	16		
Reel Position	16		
Manifold Height Adjustment	16		
Electrical Controls	16		
Nozzle Rotation Adjustment	17		
Air Flow Adjustment	18		
Removing The Manifold	18		
Maintenance	19		
Lubrication	20		
Nozzle Inspection	21		
Belt / Sheave / Idler Condition	21		
Belt Tension (FD)	21		
Belt Tension (FDX)	22		
Bearing Service	22		
Belt Service	23		
Blower Inspection	24		
Rotary Screen	24		

Introduction

Thank you for purchasing an AWS Airbar® system. This product is designed and manufactured to allow for safe operation while increasing the productivity of your harvesting operation. A well-maintained system will provide years of reliable service.

Foreword

Keep this manual with the system at all times. This manual is intended as a guide to the safe use and maintenance of the system. Before you head to the field, study this manual carefully.

Replace this manual immediately if it becomes lost.

AWS Airbar® systems are an air-assist tool to increase the productivity and efficiency of your auger or draper style combine header. This system is customized to fit your head / combine combination. The air blast provided by the system improve crop in-flow past the knife and reduce shatter related losses at the knife.

Like the other systems within your combine; the Airbar® system requires proper setup and adjustment for satisfactory operation. These instructions can be found in this manual.

You may encounter conditions where it is advantageous to remove the Airbar® manifold/nozzles temporarily.

Features:

- Belt driven, low noise fan drive, powered from the combine header drive system.
- Optimized nozzle configurations (based on reel design)
- Adjustable air flow and nozzle position
- In-cab adjustment controls

Applications:

- Dry Beans
- Soybeans
- Lentils
- Peas
- Cereals

Items Included with Airbar® Kits

- Operator's Manual
- Installation Manual

Serial Number Location

The serial number plate for the system is located on the fan housing plate. For quick reference, record the following information:

Header Model:	Date Purchased:
Serial Number:	

Replacement Parts Information

Use only genuine Original Equipment Manufacturer's (O.E.M.) replacement parts. The use of "will fit" parts may reduce system performance, void manufacturer's warranty and present a safety hazard. Use only genuine O.E.M. replacement parts. Use the QR Code below to find replacement parts.

Unauthorized Modification

Modifications to the original design of the Airbar® system, including the use of unauthorized accessories or non-genuine OEM parts, may affect the reliability of the system or make it unstable or unsafe to operate and perform as originally designed and intended. Persons or organizations that make unapproved modifications (including operation without provided guards and shields) assume all liability arising from or related to the modification including any adverse affect on the system.

No modification can be made to the original design or assembly of the Air-Bar system (including any and all attachments, safety or control devices) without the prior written consent of TEMP Farm Equipment (see contact information below). TEMP Farm Equipment Ltd. retains the right to reject all claims which arise from or are related to unauthorized modifications.

Misuse of Equipment

It is incumbent upon the user, owner and selling dealer of this equipment along with their respective employees to warn and discourage users about the misuse of the equipment whenever knowledge of misuse becomes known, whether the act has, is or could occur. Such acts include, but not limited to: riding upon, use of non-OEM parts, operating in fire-hazard areas, modifications that alter the original system specifications or use other than originally intended, etc.

Product Design

If any person, employee, agent, dealer or distributor becomes aware of any Unauthorized Modification or Misuse of an AWS Airbar® system, either past or intended, it is the responsibility of that person to ensure that TEMP Farm Equipment is notified of the occurrence promptly. That person shall provide; the facts of the occurrence, location, system serial number, name and contact information of the persons involved. Send correspondence regarding Unauthorized Modification or Misuse to:

TEMP Farm Equipment
 3890 Wellington St.
 Mitchell, Ontario, N0K 1N0
 Canada

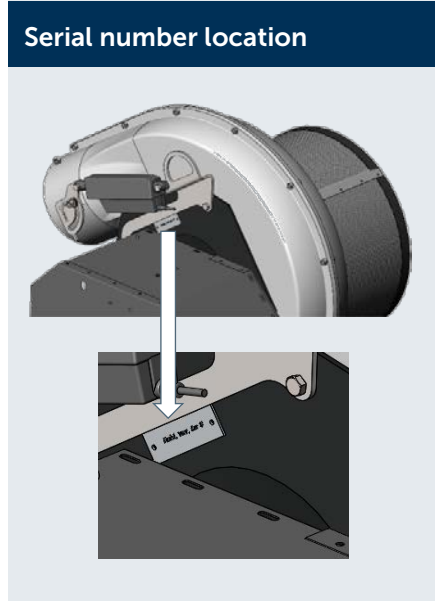

Scan above to find parts books

Official Language

No responsibility is assumed for translations in other languages, which do not correspond to the original meaning. Under our policy of continuous improvement, we reserve the right to change specifications and designs without prior notice. The illustrations shown do not necessarily represent the standard version of product offered by TEMP Farm Equipment Ltd.

Component Identification

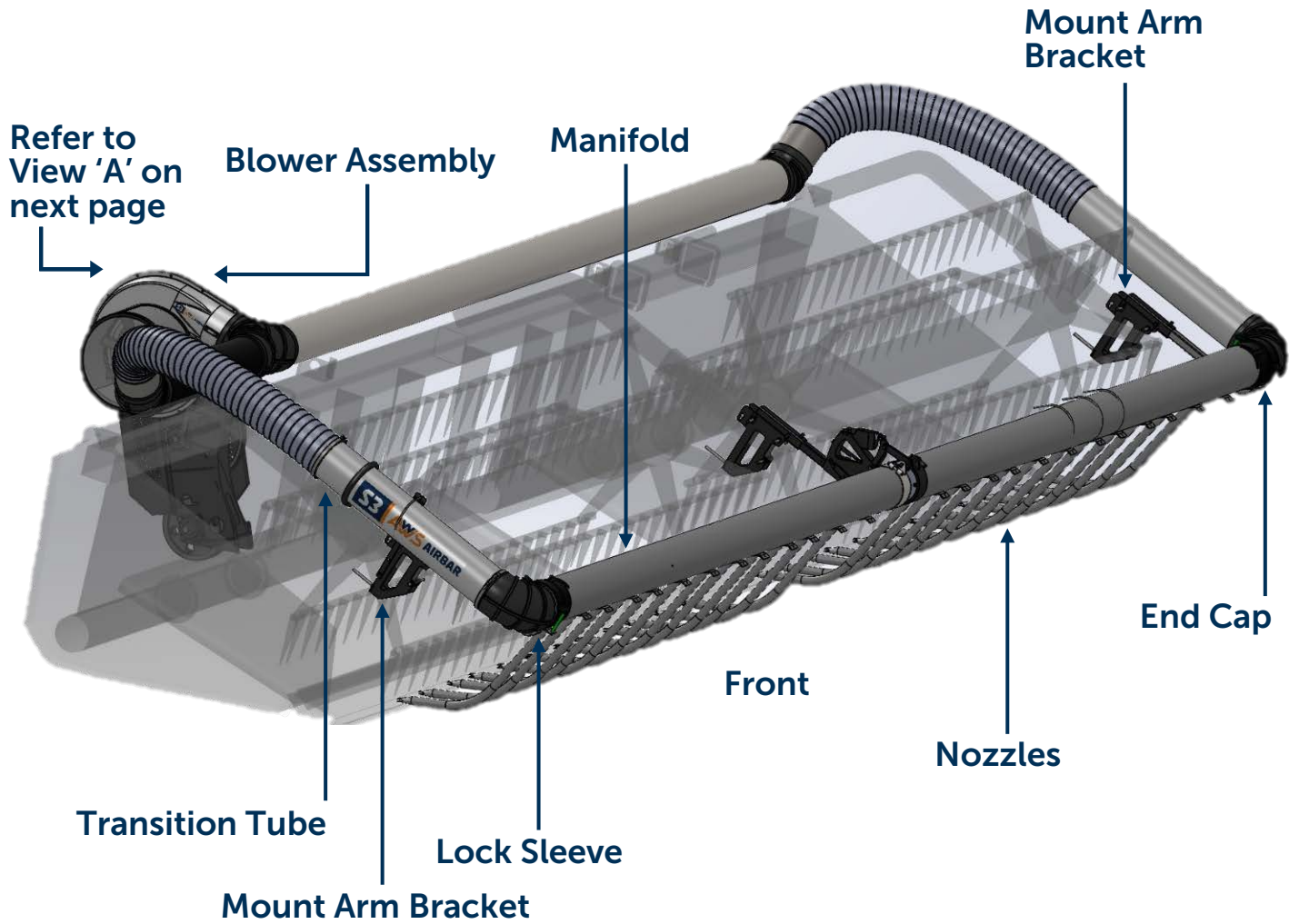

View 'A'

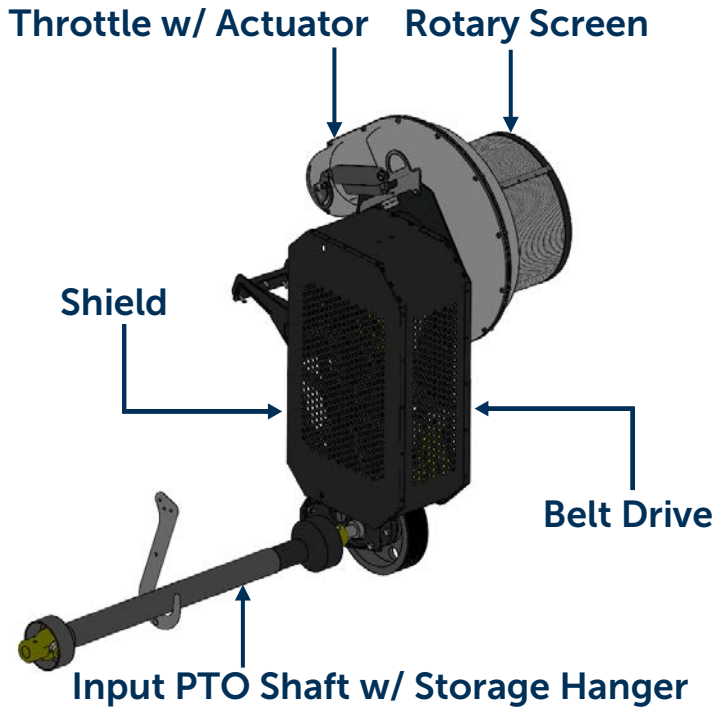

**Control Switch Box
(Installed in Cab)**

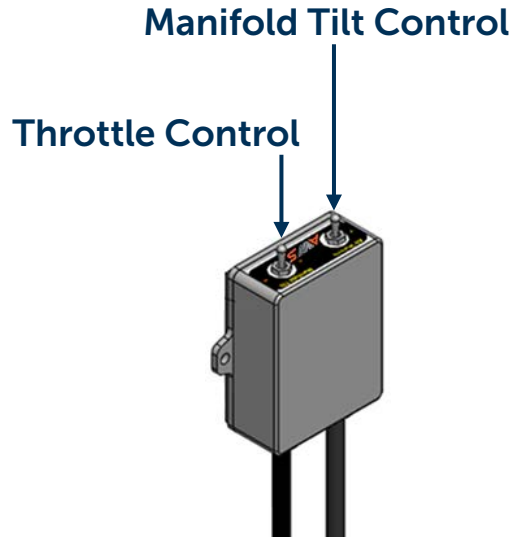

**Manifold Tilt Mechanism
Multi-Piece Reel**

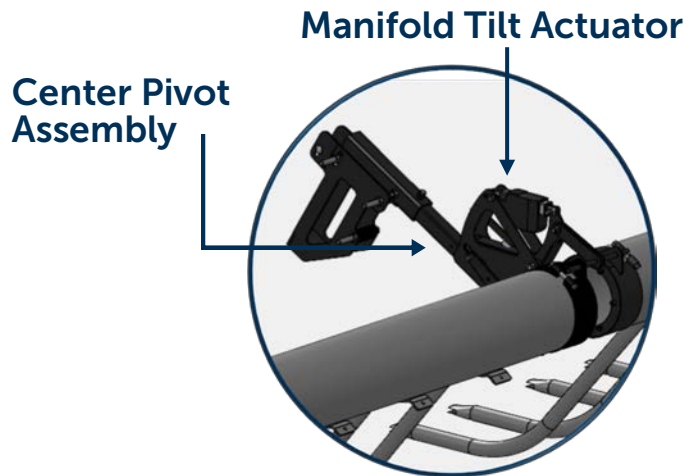

Safety

Safety Alert Symbol

This symbol appears at various points in the manual together with a signal word and warning text. It means – Be alert! Your safety is involved. This symbol is used throughout the manual to call attention to areas in which carelessness or failure to follow specific procedures may result in personal injury or component damage / malfunction or both.



Hazard Seriousness Level

The following signal words are found throughout the manual together with the safety alert symbol to indicate the seriousness level of identified hazards. Their selection is based on the consequence of human interaction with a hazard.

- **DANGER!** – Hazards or unsafe practices which WILL result in severe personal injury or death.
- **WARNING!** – Hazards or unsafe practices that COULD result in severe personal injury or death.
- **CAUTION!** – Hazards or unsafe practices that COULD result in minor personal injury or product or property damage



DANGER!



WARNING!



CAUTION!

General Safety Precautions

The operator of this system must have sufficient knowledge and instructions in the care and operation of this system and the power unit being used before he / she uses the system. Do not allow unauthorized persons or children to operate the system.

It is the obligation of the operator to make sure that all guards and shields are in place on the system. Safety decals must be in place and be readable – accidents may otherwise occur. Contact your dealer or the manufacturer for replacement manuals or decals.

- Never use a system that does not have an operator's manual available. Learn and understand the safety signs and symbols on the system and the operator instructions before you begin to use the system.
- Wear personal protective equipment. Know and use the protective equipment that is to be worn when operating or servicing the system. Hard hats, protective glasses and face shields, protective shoes, gloves, reflector type vests, and ear protection are types of equipment that may be required. Prolonged exposure to loud noise can cause hearing damage.
- Never operate a system while under the influence of drugs or alcohol. These make reflexes slow and put you and others in grave danger. Always make sure you have full concentration while harvesting.
- Adhere strictly to all regulations at the worksite pertaining to the operation of this equipment.
- Be prepared for emergencies. Have a first aid kit, fire extinguisher and emergency contact information available at the work site.



Power Unit Safety

- The operator must have sufficient knowledge in the care and operation of the power unit (combine) before connecting power unit to the system. Read and understand power unit operator's manual before connecting mower.
- Follow recommendations of power unit manufacturer. Seat belt must be worn at all times.
- Power unit must be equipped with a PTO connection matching the shaft supplied with the system. Never use PTO adapters to connect implements.
- Never exceed the feeder house speed indicated on the safety decal while the Airbar® system is in operation.



Operating Equipment Safely

- Make sure PTO shaft is properly locked. If the PTO shaft comes off during operation, personal injury or equipment damage could result.
- Never disconnect PTO shaft at fan drive. Always disconnect at feeder house end and stow in supplied hanger.
- Keep all bystanders well away from the machine when it is operating. Always maintain a safe operating distance from personnel, other equipment, or vehicles.
- Never operate the system with shields or guards removed.
- Air blast can cause small objects and debris to be blown from the header deck at high speeds. Avoid walking behind header with system operational.
- Never tamper with safety devices or operate the system with them removed. Check proper operation regularly.
- Always disengage PTO, place all controls in neutral, turn power unit off, set parking brake, and remove key before dismounting, for any reason.
- Never place hands or feet near the system components when the system is operating or power unit engine is running.
- Disengage the PTO and turn power unit off upon striking any object. Inspect system and repair any damage before continuing.
- If the equipment should start to vibrate abnormally during operation, stop the system, shut down power unit, and immediately check for the cause. Excess vibration is generally an indication of a problem. Replace bent or damaged parts, do not attempt to straighten a bent fan blade.
- Before disconnecting from power unit, always lower equipment to the ground, place controls in neutral, set park brake, turn engine off, and wait for all moving parts to stop. Relieve hydraulic pressure per power unit manufacturer's instructions.



H42442



Safety Decals

PN: AWS0062

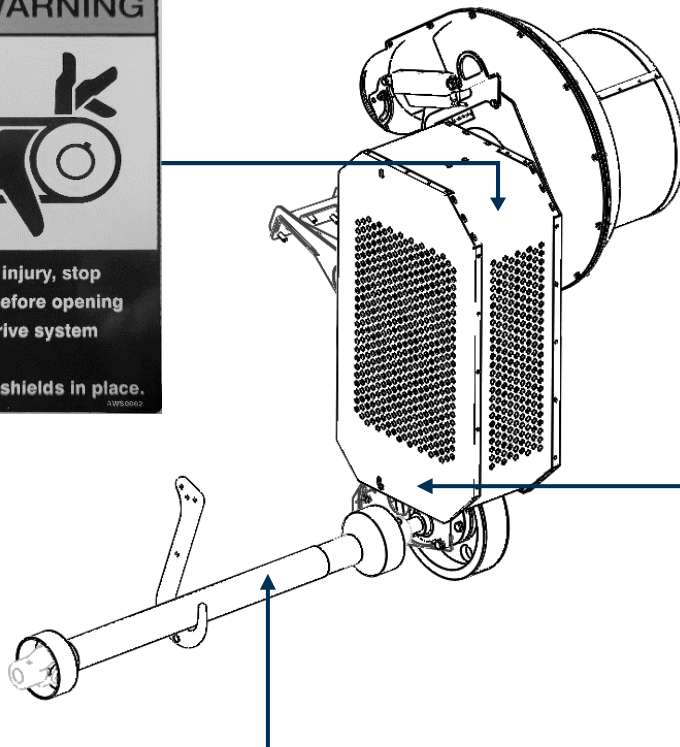

PN: AWS1053I



PN: AWS1053O



PN: AWS1052A
(John Deere, CaseIH Combines)



PN: AWS1052B
(New Holland, Agco Combines)



PN: AWS1052C
(Claas Lexion Combines)



System Setup for Operation

Feeder House Dust Extraction

If the combine is equipped with a forced-air dust extraction system for the feeder house, this feature should be disabled while operating the AirBar system. Failure to disable the dust extraction system will lead to accelerated component wear and possible failure.



When Connecting the Header

Each system is designed specifically for the intended combine to be used. Do not connect system to a different combine without consulting Temp Farm Equipment for approval. Driveline overspeed could occur.



Connecting the PTO

Ensure the feeder house drive splines are free debris and covered in a light coat of grease.

Remove telescoping PTO shaft from storage hanger and connect to feeder house shaft. Verify that the quick-attach collar fully locks. Secure shield safety chain to feeder house.

Electrical Connections

There is a single connection to be made between the combine and Airbar® system. Locate the 4-pin connector on the header harness and connect to mating connector on feeder house.

When Disconnecting the Header

Disconnecting the PTO

Disconnect telescoping PTO shaft from the feeder house shaft. Place shaft in the storage hanger.

Do not leave PTO shaft connected to the combine. Personal injury or machine damage may occur if feeder house is engaged.



Electrical Connections

Disconnect the 4-pin connector joining the combine to the header. Secure both ends of the harness to avoid damage when the system is not in use.



Electrical Controls

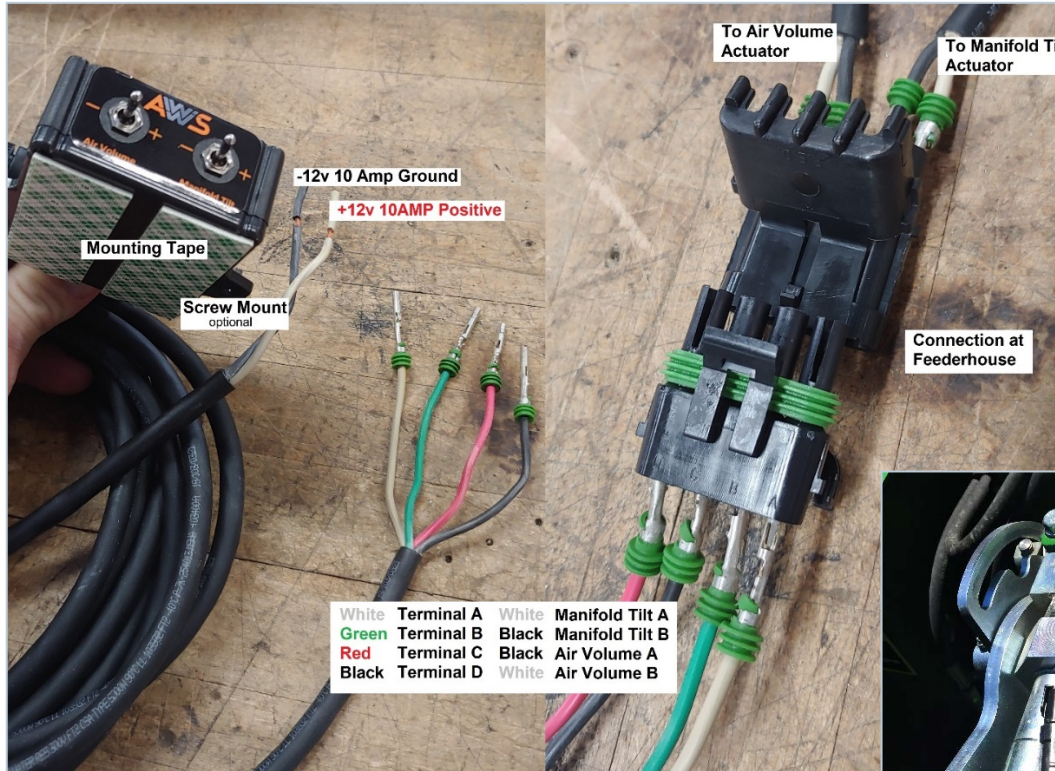

1. Mount control box in cab at convenient location. Hold 2-way tape for 30 seconds
2. Feed harness out of cab through hole in floor or right rear corner of cab.
3. Route harness to left hand side of feederhouse and attach near single point connection.
4. Secure harness using provided zip ties.
5. Insert terminals into male housing as per above and snap secondary lock.
6. Route the **air volume** & **manifold tilt** harness's along back of header to feederhouse connection.
7. Install male terminals loose into combine connector to check polarity on switch box +/- is correct
8. Insert terminals into female housing (header harness) and lock connector.

Operating the System

Daily Checks

Component	Checks
Safety Shields	In place
Rotary Screen	Rotates freely Clear of trash
Nozzles	Proper nozzle opening Properly secured to manifold No bent / broken nozzles
Electric Controls	Throttle & manifold tilt actuators function properly
Electrical Connection	Plugs secured at header Harness is secured

Reel Position

The use of the Airbar® system aids not only in reducing shatter loss but also the inflow of crop material, assisting the finger reel system.

In most cases, shatter loss can be reduced further with the ability to set the finger reel higher than if an Airbar® system is not used.

When entering the crop, begin with the reel the "normal" height and begin to raise the reel until you see a decrease in performance.

Manifold Height Adjustment

The manifold height can be adjusted in accordance with the desired reel position. In most applications the mid-height adjustment hole is appropriate.

It is important that the "heel" of the nozzle (area of the bend) is 2-4" higher from the ground than the nozzle tip when in the operating position.

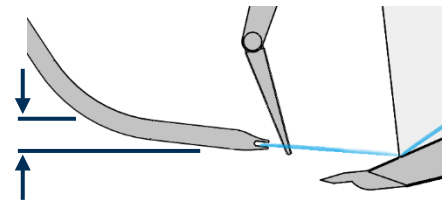

Electrical Controls

All nozzle and air flow adjustments for the Airbar® system are made using the electrical switch box installed in the cab.

There are 2 separate switches:

Switch	Action
1 - Air Volume (Cycles Throttle Actuator)	+ Increase Air Output - Decrease Air Output
2 - Nozzle Tilt (Cycles Manifold Tilt Actuator)	+ Tilt Nozzle toward head - Tilt Nozzles Away from Head

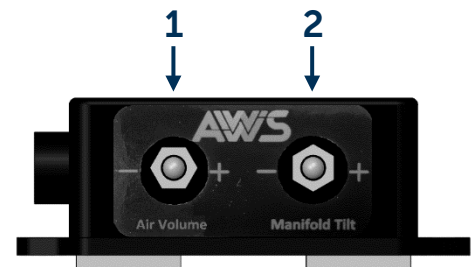

Nozzle Rotation Adjustment

The most important adjustment affecting the performance of your Airbar® system is the position of the nozzles.

The nozzles should be aimed so that the air blast contacts the head 2" – 5" behind the knife.

This position will allow for loose crop material to be swept into the header as well as aid in lifting the crop mat into the infeed system on the header (auger or canvas). The crop mat should "float" on a cushion of air similar to an air-hockey puck.

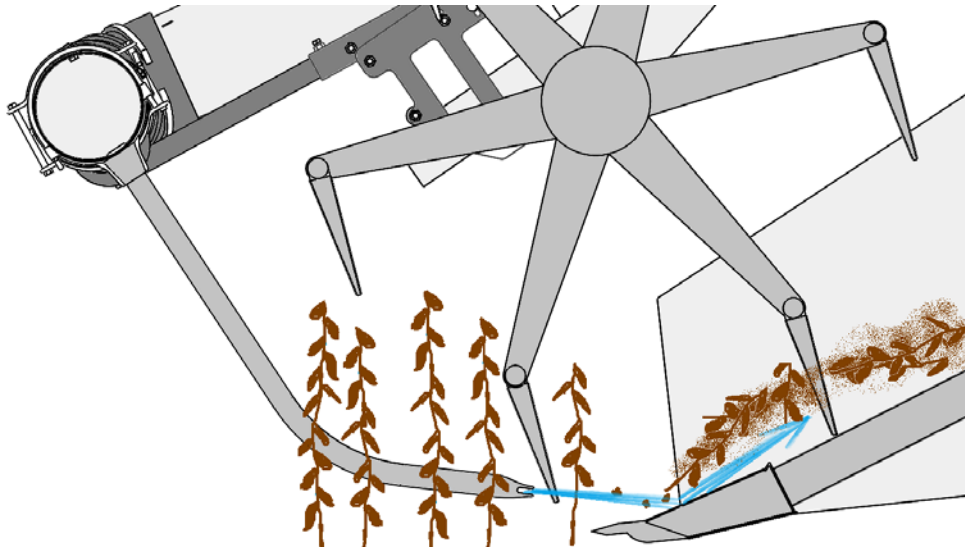

Indicators of improper nozzle adjustment are:

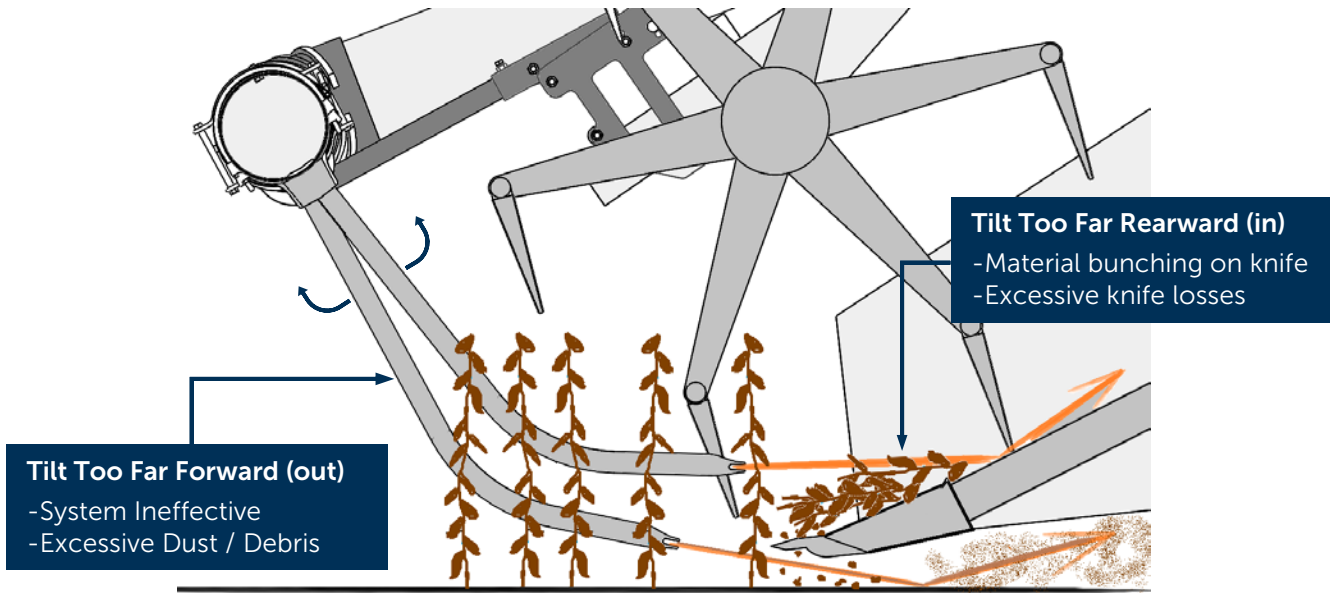

Air Flow Adjustment

The AWS Airbar® system is designed to be capable of providing excess air flow in most applications. The electric throttle control is provided to allow for optimization of the air flow regardless of harvest conditions.

NOTICE - The use of excess air flow not only leads to increased crop loss but also consumes excess power; leading to increased component wear and fuel consumption.

To Adjust Air Flow:

- Position and the air throttle at the full-open position.
- Close the throttle a bit at a time, observing the crop flow over the knife after each adjustment.
- At the point where you see the crop flow worsen, open the throttle back up to the previous position.
- This is the most efficient setting for those conditions.

This setting should be checked periodically through the day as well as from field to field. Plant moisture content, yield, and plant population will affect where the throttle should be positioned.

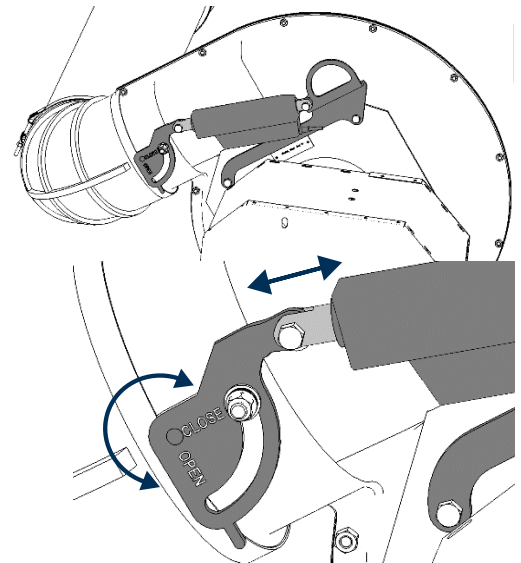

Removing The Manifold

In certain down or tangled crop conditions it is desirable to remove the Airbar® manifold and nozzles for proper crop recovery. This can easily be done using the following procedure:

Multi Piece Reel

LH Manifold

1. At center pivot remove (1) 3/8x5 bolt & nut clamping manifold to center pivot.
2. With a person at each end of the manifold, lift center pivot end and rotate to disengage lock sleeve bushing.
3. While supporting the LH end of the manifold, Pull manifold away from air feed elbow.
4. The manifold is now free from the header, hang or store in a safe location.
5. Re-install bolts on center pivot clamp.

RH Manifold

6. On RH end (at center pivot), remove the RH clamp bolt securing the manifold to the center pivot assembly.
7. With a person at each end of the manifold, lift center pivot end and rotate to disengage lock sleeve bushing.

Steps 1 & 6

Removing Center Pivot Clamp. (Multi Piece Reel)

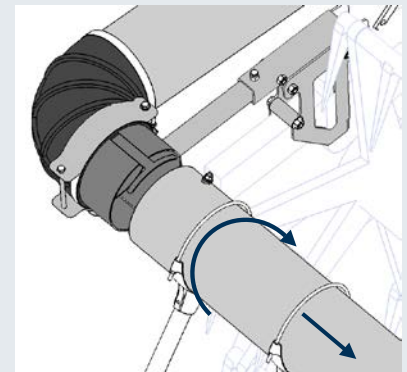
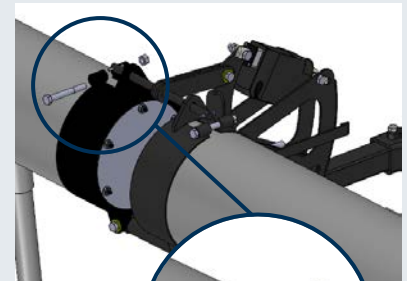

8. While supporting the RH end of the manifold, Pull manifold away from air feed elbow.
9. The manifold is now free from the header, hang or store in a safe location.
10. Re-install bolt on center pivot clamp.
11. Ensure PTO shaft is disconnected from the feeder house and stored properly.

Maintenance

Ensure the combine controls are in the park position, the engine is turned off, head is in the parked position, the parking brake is engaged, and hydraulic pressure has been relieved before performing service or maintenance.

Perform all maintenance with the head in the lowered position and the machine on a flat and level surface.

Always use personal protection devices such as protective glasses and face shields, protective shoes, gloves, hard hats, and ear protection when performing service or maintenance functions.

When completing a maintenance or service function, ensure all safety shields are installed before placing system in service.



WARNING!

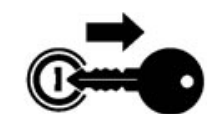

Service	Maintenance Intervals	
	Weekly	Annual
Inspect Nozzles	✓	
Grease PTO Shaft	✓	
Grease Bearings	✓	
Check / Adjust Belt Tension	✓	
Inspect Rotary Screen	✓	
Inspect Fan Impeller	✓	
Inspect Manifold	✓	
Inspect Pulleys/Sheaves		✓
Inspect Bearings / Idlers		✓
Inspect Framework / Fasteners		✓



Scan above to find parts books.

Lubrication

Grease specifications: all greases are not compatible. Use of incompatible greases will decrease lubrication qualities and can cause premature component failure.

- Specification: NLGI GL-2
- Grease Type: Mineral Oil, Lithium Soap Thickener

Grease of this type is considered "general purpose". It can be used on all components of the Airbar® system.

Please note:

1. Do not use "high-temperature" greases. Normal operating conditions of this system will not exceed the recommended temperature range of conventional grease. High-temperature greases may use thickeners not compatible with OEM grease.
2. Do not use "MOLY" greases (molybdenum disulphide additives). These greases are not suitable for extended use with rolling element bearings.
3. Do not use greases with synthetic base oils. These synthetic components may not be compatible with OEM grease.

PTO Shaft

- Location A – 4-6 Pumps (15 grams)
- Location B – 2-3 Pumps (6 grams)
- Location C* – 4-6 Pumps (15 grams)

*Note – Pull PTO shaft apart & apply grease to inner profile.

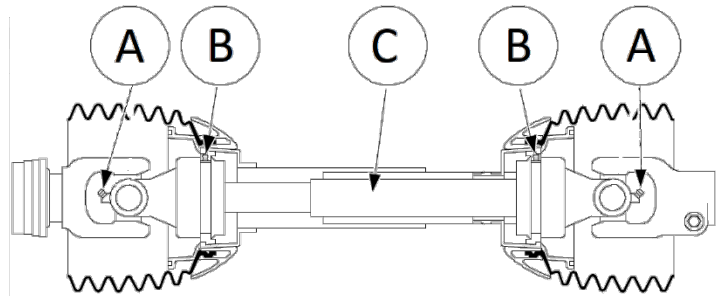

Bearings

The (4) shaft bearings are the only grease points on the main chassis, (2) on each side.

On some 35' and 45' systems (equipped with an extended driveline), there is an additional bearing that requires greasing.

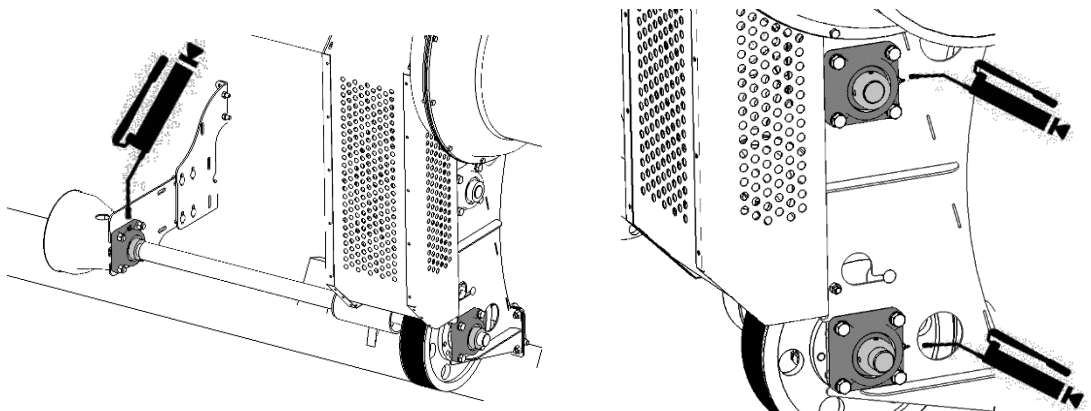

Nozzle Inspection

Opening

It is critical that the nozzle opening be set to 3/8". They can become collapsed or opened during use from contact with rocks and other debris and wear.

To check & set the opening, a 3/8" bolt can be used. To set the opening, insert the bolt and pinch using pliers as shown.

U-Bolt

Vibrations from normal use can cause the gasket between the nozzle yoke & manifold to take a set, reducing tension in the U-bolt. Check tightness of U-bolt nuts periodically using a 7/16 wrench or deep socket.

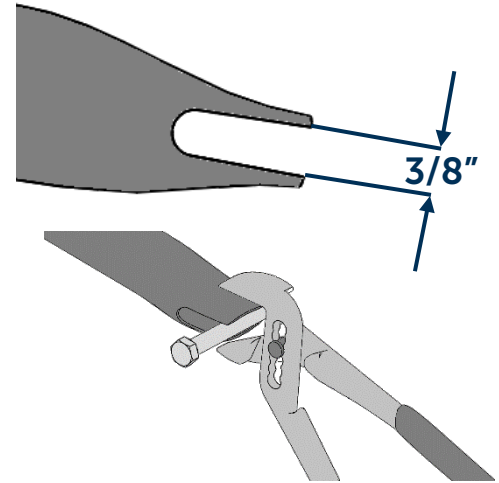

Belt / Sheave / Idler Condition

Inspect all belts, sheaves and idlers for good condition.

Belts should appear supple with no shiny appearance on the drive surface or cracks on the inner or outer surface.

Belts should not sit in the bottom of the sheave grooves or the inner ribs between grooves should not be worn to a point. If either of these cases exist, the sheave is worn excessively and should be replaced.

Idler pulleys should be in-line with the belt running path and parallel with the sheaves. If the idler is not in-line or parallel, inspect the idler bearing condition or the bronze bushings on which the idler pivots for wear. Replace as required.

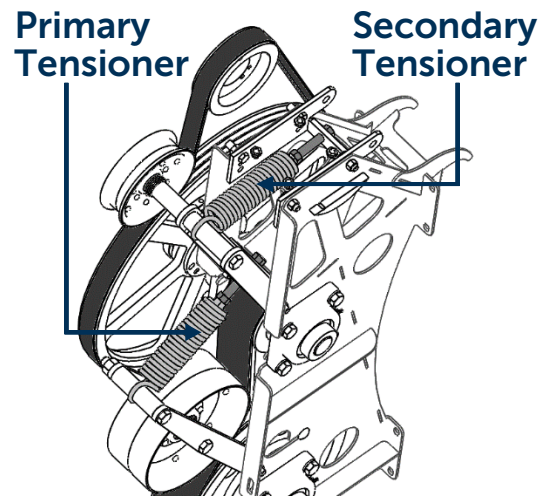

Belt Tension (FD)

Proper belt tension is critical to both optimum performance and long life of your Airbar® system. Loose belts will create excessive heat and ultimately fail. Belts that are too tight can lead to accelerated bearing failure.

Belt tension is set using a draw-bolt to extend a spring. The extended spring maintains tension.

On initial tensioning of new belts, tighten the draw bolt until a 1/8" gap is present between the spring coils (roughly the thickness of two quarters). Once initial run-in is completed, maintain a minimum 1/16" (roughly the thickness of a quarter) gap in the spring.

It is important to set the secondary belt tension first, then the primary. Double-check the secondary belt tension after setting primary tension.

1/8" (2x "Quarter" Thickness) – Initial
1/16" (1x "Quarter" Thickness) – Run-In

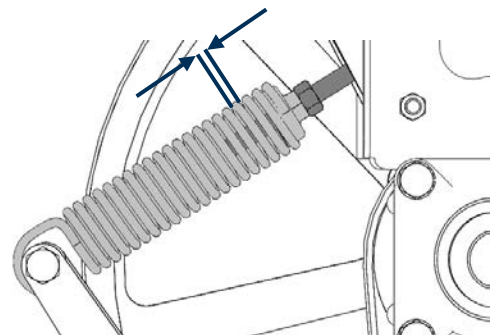

Belt Tension (FDX)

Proper belt tension is critical to both optimum performance and long life of your Airbar® system. Loose belts will create excessive heat and ultimately fail. Belts that are too tight can lead to accelerated bearing failure.

Belt tension is set in the factory using the RunRight® Lovejoy tensioners. These tensioners should maintain proper tension through out the life of the belt. If belt slip becomes excessive a new belt can be ordered to maintain your system.

The primary tensioner should be set to the "HARD" position and the secondary set to "NORMAL".

Bearing Service

The spherical bearings used on the Airbar® drive system are secured to the shafts using eccentric locking collars.

NOTE – Always apply anti-seize compound to shaft before mounting bearing.

To Secure the Collars

1. Slide the eccentric collar against the mating end of the insert inner race.
2. Snug the collar on the mating eccentric in the direction of shaft rotation.
3. Place a mild steel bar inside the hole provided by the collar and tap the collar sharply in the direction of shaft rotation and perpendicular to the shaft.
4. Tighten the setscrew in the collar to the proper torque (156 in-lb).
5. Re-check tightness of the setscrew and hold down bolts after 24 hours of operation to insure nothing has loosened.

To Remove the Collar

- Loosen the setscrew, then tap the collar in the direction opposite the shaft rotation.

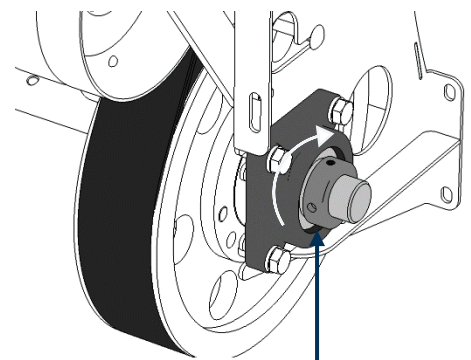
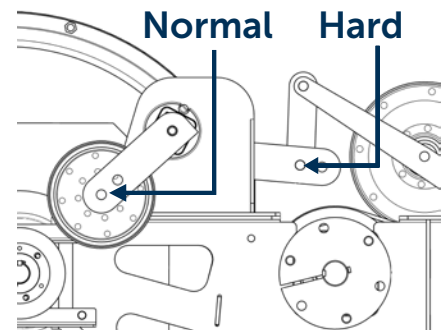
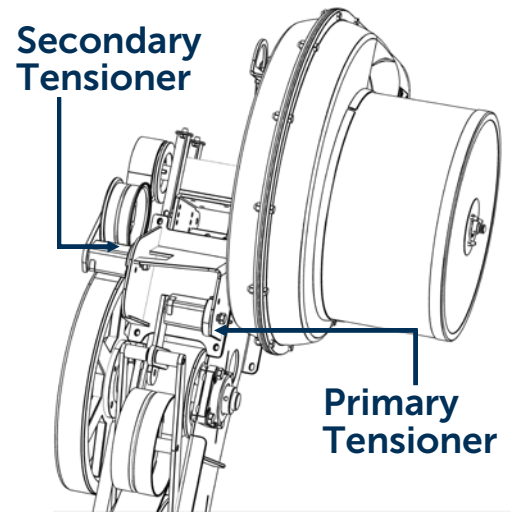

Belt Service

From 2021, all AWS Airbar® systems are delivered with the new ServiceMaster chassis. This chassis design allows for primary belt change-out in up to 70% less time than the previous designs.

Belt Removal

It is not required to remove the bearings from the shaft to change the primary belt:

1. Remove Shield
2. Release tension from primary belt & remove idler pulley or tensioner arm assembly.
3. Release tension from secondary belt & remove belt
4. Beginning with the top shaft, remove bearing bolts at front of chassis.
5. LOOSEN bearing bolts at rear of chassis.
6. Slide top shaft assembly out of chassis toward rear and remove from belt. Set aside.
7. Repeat above steps for bottom shaft and remove belt.

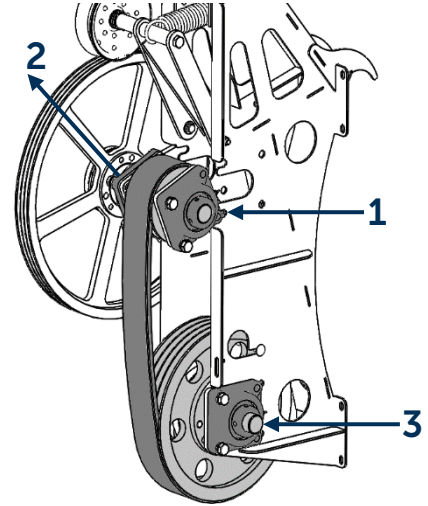

Inspection

8. Inspect sheave condition.
 - a) Drive surfaces should be smooth and free from pitting or grooves.
 - b) The bottom of the groove should show no sign of wear.
 - c) If available, use a commercially available groove gauge to determine condition. In no circumstance should the land between grooves be a sharp edge.
9. Inspect tensioner condition.
 - a) Ensure bronze pivot bushings are in good condition and rotate freely in tensioner arm.
 - b) Use of impact tools to tighten pivot joints can deform bronze bushings, causing binding of the pivots and premature belt failure.

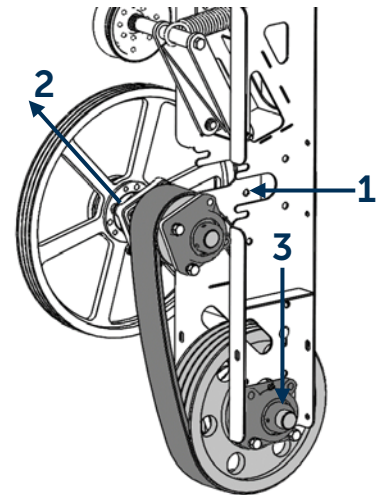

Reassemble

10. Repeat steps 1-7 in reverse order to install new belt.
11. Tension belts per method shown on page 21.

Blower Inspection

Remove rotary screen & inspect all impeller blades.

Replace impeller if any of the fins are loose or if wear has reduced the width of the fin.

Clean housing and impeller removing all debris.

Rotary Screen

From 2022, all AWS Airbar® Blowers are equipped with a cleaning nozzle to remove debris from the circumference of the rotary screen in conjunction with the rotary screen brush.

The nozzle provides a steady stream of air over the clean-off area of the screen to remove leaves and debris as the screen rotates.

If the nozzle provides sufficient cleaning alone, the brush may be removed for operation.

When clean, the screen should be free to rotate without any contact with other parts. If there is contact between the outer screen and inner support, manually manipulate the screen to eliminate contact.

Ensure all internal blades are in good shape and bearings rotate smoothly without excessive noise.

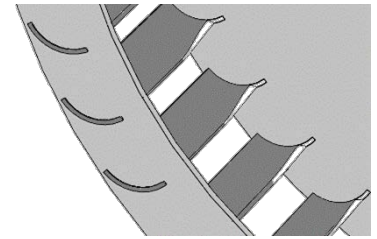

Typical wear pattern

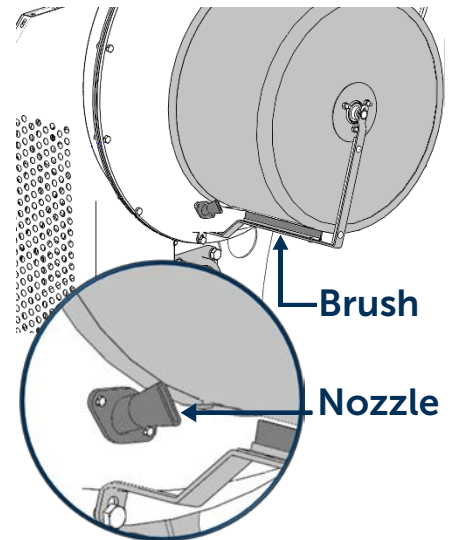
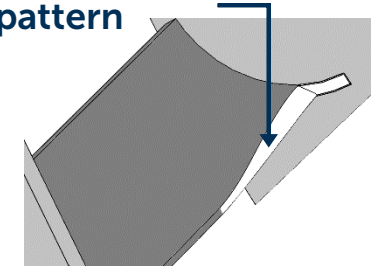

Manifold / Air Ducting

Flex Hose

Inspect flex hose for signs of weather cracking & wear.

To maximize flex hose life & ensure even wear rotate the hose 45° before the start of each season.

Manifold Rotation

The manifold is supported by 2 saddles which allow it to rotate via the electrical actuator. This must be kept lubricated for proper operation.

Apply a dry-film (graphite or PTFE) lubricant to the lock sleeve & end cap areas annually or before use.

Cleaning Manifold

During operation, a large amount of dust and debris is transferred through the air duct system. What is not discharged through the nozzles will collect at the end of the manifold. It is important to clean this annually to prevent the debris from clogging nozzles and reducing system performance.

Remove center-caps from each manifold and vacuum any debris collected during the previous harvest season.

Fastener Torque

The chart below lists the proper installation torque for fasteners on Airbar® systems. When bolts are to be tightened or replaced, refer to this chart to determine the proper torque (unless otherwise specified in this manual).

SAE Grade 5 fasteners are used in the assembly of the system, unless otherwise specified in this manual.

Bolt Grade / Class Identification

SAE Gr 2	SAE Gr 5	SAE Gr 8
No Dashes	3 Dashes	6 Dashes

Bolt Diameter	Std. Nut Recommended Torque	Stover Lock Nut Recommended Torque
1/4	86 in-lb	93-144 in-lb
5/16	178 in-lb	192-251 in-lb
3/8	26 ft-lb	28-37 ft-lb
1/2	64 ft-lb	69-90 ft-lb

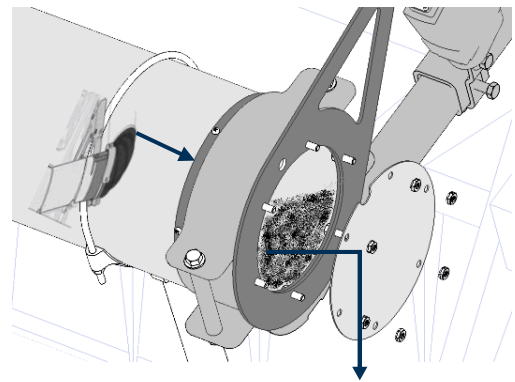
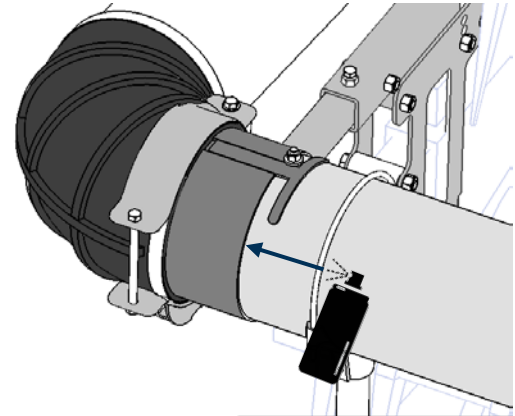

Troubleshooting Guide

Problem	Possible Cause	Solution
Low Air Flow / Poor Performance	Improper Nozzle Opening (Too Wide)	Check / Adjust Nozzle Opening (See page 21)
	Missing / Broken Nozzle(s)	Replace Nozzle(s)
	Damaged Flex-Hose	Replace Flex-Hose
	Plugged Nozzles / Manifold	Remove end-cap /nozzles, inspect & clean (See page 25)
	Loose / worn belts	Inspect & adjust / replace as required (See page 21 & 23)
Rapid belt wear	Improper tension	Adjust to specification (See page 21)
	Worn sheave(s)	Inspect & replace as required (See page 23)
	Worn belt(s)	Inspect & replace as required (See page 23)
	Binding in Tensioner Pivots	Inspect bronze bushings in tensioner arms for binding (See page 23)
Electrical Actuator Inoperative	Wiring Fault	Connect 12/18V battery to actuator (at connector) to verify operation in both directions If actuator functional, check all wiring connections
	Blown Fuse	Inspect & replace as required (located in switch box or combine power feed)